

# delta

# 2000 LD



[www.ilapak.com](http://www.ilapak.com)



PACKAGING MACHINERY

## TECHNICAL SPECIFICATIONS

<b>Machine speed</b>	Up to 60 cycles per minute Production output depends on film sealability and product characteristics.
<b>Product dimensions</b>	
<b>LENGTH</b>	Up to 600mm - 24"
<b>WIDTH</b>	300mm - 12" (jaws 345mm - 13.6")
<b>HEIGHT</b>	Up to 110mm - 4.0" standard (centre-axle 180) Up to 140mm - 5.5" on request (centre-axle 215)
<b>Film cut off</b>	Min 100mm - 4" / Max 650mm - 26" Depending on film and product characteristics.
<b>Wrapping materials</b>	Shrink barrier films, laminated, co-extruded and all sealable films
<b>Film reel dimensions</b>	
<b>CORE Ø</b>	76.2mm - 3" standard 152.4mm - 6" on request
<b>OUTER Ø</b>	350mm - 13.8" standard 400mm - 15.7" on request (auto-splicer only)
<b>WIDTH</b>	800mm - 31.5" standard 500mm - 19.7" standard (wet-wipes only) 650mm - 25.6" on request 900mm - 35.4" on request
<b>Film reel max weight</b>	Depending on film reel width, up to 75 kg - 165 lbs
<b>Electronic platform</b>	Industrial PC For USA & Canada, in particular, Allen Bradley platform available.
<b>Power requirement</b>	From 220 to 480 V, 50/60 Hz, 5kVA
<b>Compressed air</b>	6 bar, 200l/min
<b>Machine weight</b>	1200 Kg - 2700 lbs

## MAIN STANDARD FEATURES

- Long-dwell sealing head to optimize sealing cycle.
- 3 servo motors to control infeed, rollers, jaws (additional motors with automatic feeders).
- User friendly operator interface with intuitive icons on 10" colour VGA touch screen.
- 128 programs (additional memory on request).
- Automatic product size change.
- Integrated temperature control.
- Electronic diagnostic on-board.
- No product/ no bag.
- Misplaced product detection system.
- I/O for peripheral units (printer, labelers, gas control, etc.)
- Single film reel mounting with self-centering cones, right hand machine version, 3m long infeed, standard.
- Robust, hygienic, easy to clean design, stainless steel finishing standard.

Please discuss your needs with our local representative to configure these machines to your product's specific requirements.

ILAPAK is ISO 9001:2000 certified

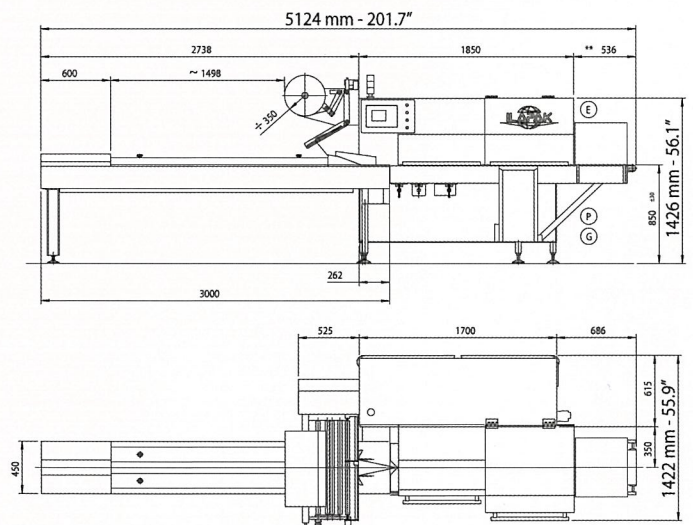

All measurements not specified in inches are given in millimeters.

These specifications are not binding. We reserve that right to change them without prior notice.